



Intelligent frequency conversion circulation pump

Model:WB-APE

EEI≤0.23



Warning

Ground motor before connecting to power supply.
Do not touch the pump while it is running.
Do not run the pump without water.





Troubleshooting



Symptom	Likely causes	What to do
The pump is not working	Loose power cable connection	Make sure the power cable is connected securely and firmly
	Blown fuse	Replace the fuse
	The impeller, motor may be wound by fibers or jammed with debris	Clean the fibers and debris
Noise within system or pump casing	Debris within pump	Dismantle the pump and clean the debris
	Flow rate is set too large	Switch to lower speed
	Air or gas within system or pump casing	Exhaust the air or gas
The pump is working, but not generating any pressure	Intake valve is closed	Open the valve
	Air or gas within pipes or pump	Open the valve to make the pump running and meanwhile loosen the connector of the outlet ports to ensure gas emission

- All the figures in this manual are schematic diagrams, and please understand that the electric pumps and accessories you buy may be different from the diagrams in this manual.
- The performance of the product is improved constantly, and all products (including appearance and color, etc.) are subject to physical products; no further notice will be given in case of any change.

Notes:

In case of failures, the electrical controller will react to some of the faults and protect the pump. The protection code on the display panel shows in the following table:

Protection type	Display	Likely causes	What to do
Locked-rotor protection		The rotor is blocked	Disassemble the motor and check if the rotor can rotate normally. If not then clean up the debris to make the rotor part rotate freely
Overvoltage/undervoltage protection		The input voltage is too high or too low	Check if the voltage is within normal range, if not then adjust to

			normal voltage
Open phase protection		One or more phases of the internal connection circuit is disconnected	Replace the pump
Over current protection		Short circuit of internal connection circuit	Replace the pump

5.4.6 Signal connection

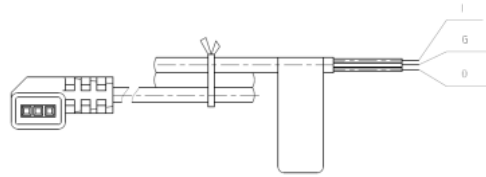

Black: Ground wire (GND)
 Red: PWM input (from controller) Yellow: PWM output (from the pump)

6 Technical data

Supply voltage	220~240V 50/60Hz			
Motor protection	Doesn't need external motor protection			
Protection class	IP44			
Insulation class	E			
Relative ambient humidity	Max. 95%			
System pressure	Max. 1.0 MPa, 10 bar			
Suction inlet pressure	Liquid temperature	≤ +75 °C	Min. Inlet pressure	0.05bar, 0.005MPa
		+90 °C		0.28bar, 0.028MPa
		+110 °C		1.08bar, 0.108MPa
EMC Standard	GB 4343.1	GB 4343.2	GB 17625.1	GB 17625.2
Ambient temperature	0°C ~ 40°C			
Surface temperature	Max. +125°C			
Liquid temperature	+2°C ~ +110°C			

CONTENTS

1 Introduction	2
2 Profile and dimensions	2
2.1 Model instructions	2
2.2 Model and function overview	2
2.3 Dimensions	3
3 Cautions	4
4 Using environment and installation	4
4.1 Pumped liquids	4-5 6
4.2 Liquid temperature and ambient temperature	7 8 9
4.3 Installation	9
4.4 Control box positions	9
4.5 Electrical connector	10
	11
5 Operation instructions	
5.1 The control panel	
5.2 Performance curve	
5.3 Relationship between electric pump setting and lighted area	
5.4 PWM	12-15
	15 16
6 Technical data	
7 Troubleshooting	



Thank you very much for choosing our company's products. Please read the instructions carefully and save it properly before installation and use.



Warnings

- Please read the instructions carefully before installation and use.
- The electric pump must be reliably grounded and installed with leakage protection devices before use.
- It is strictly forbidden to touch the electric pump during operation.



Warning for Children

It is strictly forbidden for children, incapacitated persons, or person limited in disposing capacity (If have not been taught how to use this product safely and understand the hazards involved) to use this product without supervision by a guardian

Electricity Warning



The electric power system may be used only when it has the safety protection measures specified by the existing provisions of the country where the product is installed.



Pressure Warning

The pump system must be able to withstand the maximum pressure of the pump.

Modification-related Warning



The manufacturer is not responsible for any consequences caused by the user changing the electric pump or operating the electric pump beyond the operating conditions

5.4.4 PWM signals

Galvanic isolation in pump	YES
PWM frequency input	1000–2500Hz
Input voltage high level U_{IH}	4.0–5.5V
Input voltage low level U_{IL}	< 0.7V
Input current high level I_H	Max3.5mA@4700Ohms Max10mA@100Ohms
Input duty cycle PWM	0–100%
Signal polarity	fixed
Signal cable length	< 3m
Rise time, fall time	< T/1000

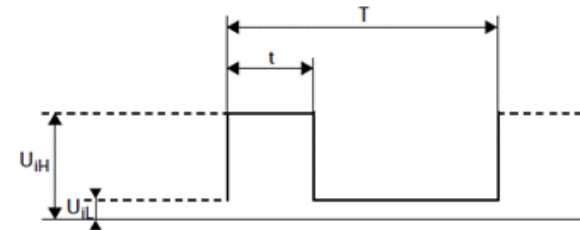

5.4.5 PWM feedback signal (power consumption)

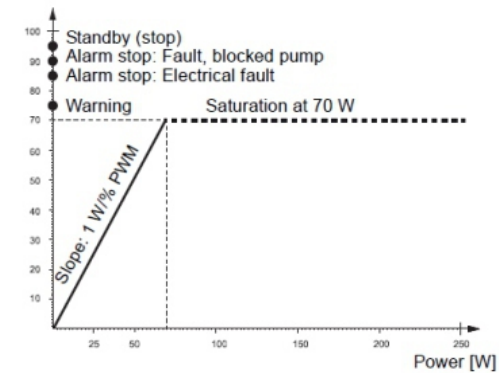

PWM output signal (%)	Qualification time or (s)	Pump information	Disqualification time or (s)	Priority
95	0	Standby by PWM signal (STOP)	0	1
90	30	Alarm, stop, blocked error	12	2
85	0–30	Alarm, stop, electrical error	1–12	3
75	0	Warning	0	5
0-70		0–70W (slope 1W/%PWM)		6
Output frequency	75Hz±5%			

PWM input signal (%)	Pump status
0	Switch the pump to non-PWM mode (internal control) operation
$0 < PWM \leq 10$	Maximum speed: Max.
$10 < PWM \leq 84$	Variable speed: max. to min.
$84 < PWM \leq 91$	Minimum speed: Min
$91 < PWM \leq 95$	Hysteresis area: on/off
$95 < PWM \leq 100$	Standby mode: off

5.4.3 PWM input signal (P2 solar)

At low PWM signal percentages (duty cycles), a hysteresis prevents the circulating pump from starting and stopping if the input signal fluctuates around the shifting point. Without PWM signal percentages, the circulating pump will stop for safety reasons. If a signal missing, for example due to a cable breakage, the circulating pump will stop avoid overheating of the solar thermal system.

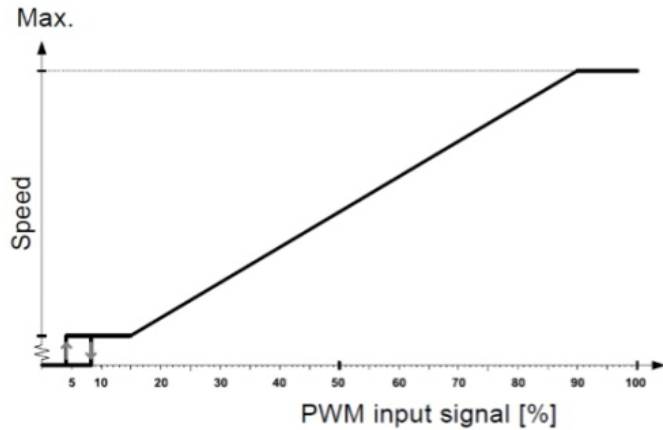

PWM input signal (%)	Pump status
0	Stop running
$0 < PWM \leq 5$	Standby mode: off
$5 < PWM \leq 8$	Hysteresis area: on/off
$8 < PWM \leq 15$	Minimum speed: Min
$15 < PWM \leq 90$	Variable speed: min. to max.
$90 < PWM \leq 100$	Maximum speed: Max.

1 Introduction

APE intelligent frequency conversion circulation pump (hereinafter called as "electronic pump"). The stator of the motor is completely shielded, and the rotating parts are immersed in clean water, playing an important role in cooling and lubricating during working. The shielding sleeve of the electric pump adopts thin-wall structure to completely shield the internal stator of the motor from water, the traditional mechanical seal structure is eliminated and the leakage problem of conventional water pump is solved. The rotating parts are made of ceramic bearings and ceramic rotating shafts, which are wear-resisting and lubricated with clean water, can cold down the motor and reduce the noise. The pump will not overload during full head running. It can be generally free from maintenance as long as used correctly.

2 Profile and dimensions

2.1 Model instructions

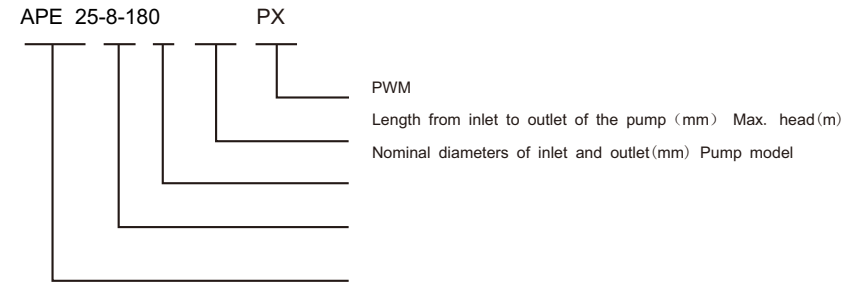

2.2 Profile

Model	Inlet/Outlet diameter	Thread	Max flow	Head	Voltage	Frequency	Power	Current				
	mm		m ³ /h						m	V	Hz	W
APE20-4-130(P1/P2)	20	G1	2.2	1~4	220~240	50/60	25	0.3				
APE25-4-130(P1/P2)	25	G1.5	2.5									
APE25-4-180(P1/P2)	25	G1.5	2.5									
APE32-4-180(P1/P2)	32	G2	2.9	1~6			220~240	50/60	45	0.5		
APE 20-6-130(P1/P2)	20	G1	2.9									
APE25-6-130(P1/P2)	25	G1.5	3.2									
APE25-6-180(P1/P2)	25	G1.5	3.2	1~8					220~240	50/60	65	0.65
APE32-6-180(P1/P2)	32	G2	3.6									
APE20-8-130(P1/P2)	20	G1	2.9									
APE25-8-130(P1/P2)	25	G1.5	3.4	1~8	220~240	50/60					65	0.65
APE25-8-180(P1/P2)	25	G1.5	3.6									
APE32-8-180(P1/P2)	32	G2	4.0									

Model	Internally controlled			Externally controlled
	Proportional pressure	Constant pressure	Constant curve	PWM
APE XX - X - XXX	I	I	I	P1
	II	II	II	
	III	III	III	
	AUTO	/	/	
APE XX - X - XXX P1	/	/	III	P1
APE XX - X - XXX P2	/	/	III	P2

2.3 Dimensions

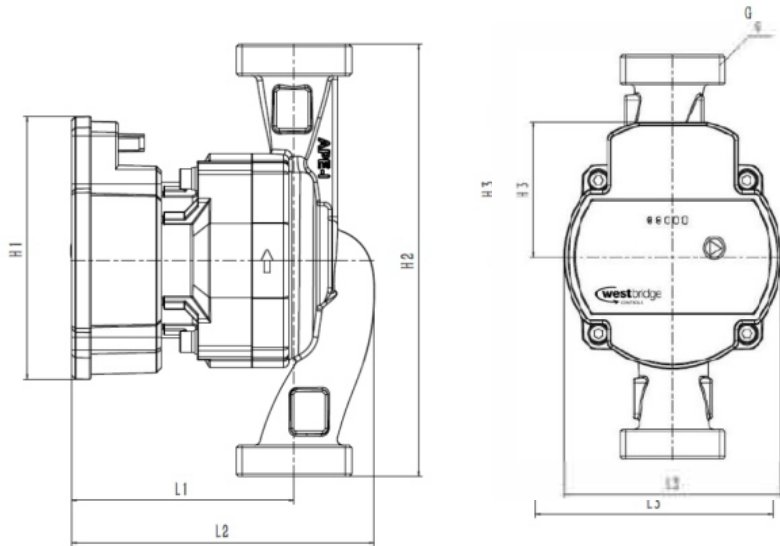

Model	Size (mm)						
	L1	L2	L3	H1	H2	H3	G
APE20-X-130 (P1/P2)	93	126	99	110	130	60	G1
APE25-X-130 (P1/P2)							G1.5
APE25-X-180 (P1/P2)					180		G1.5
APE3X-180 (P1/P2)					G2		

5.4 PWM

5.4.1 Control principles

When PWM signal is connected, the operation of circulating pump is controlled by PWM signal. If there is no PWM signal, the operation of circulating pump is controlled by internal control logic.

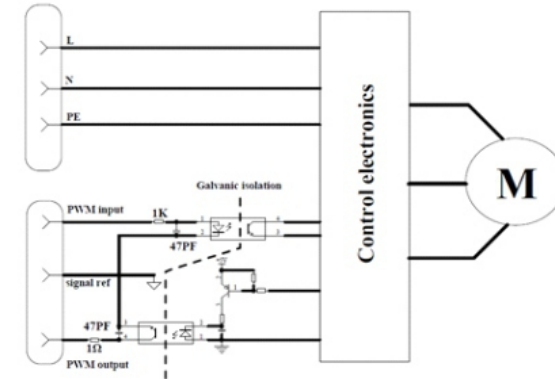

5.4.2 PWM input signal (P1 heating)

At high PWM signal percentages (duty cycles), a hysteresis prevents the circulating pump from starting and stopping if the input signal fluctuates around the shifting point. At low PWM signal percentages, the circulating pump speed is high for safety reasons. In case of a cable breakage in a gas boiler system, the circulating pump will continue to run at maximum speed to transfer heat from the primary heat exchanger. This is also suitable for heat circulating pumps to ensure that the circulating pump can transfer heat in case of a cable breakage.

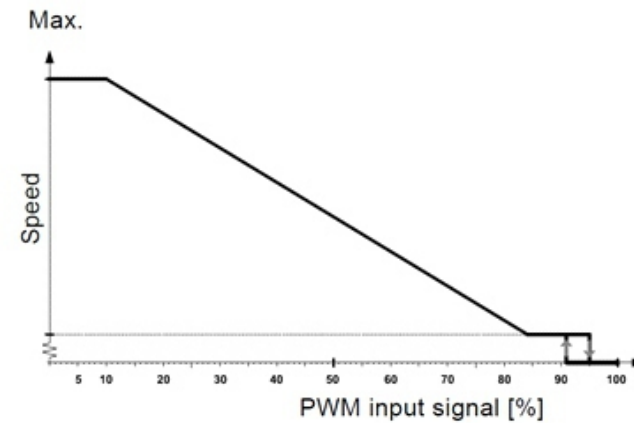

5.3 Relationship between electric pump setting and lighted area

Electric pump mode is setup with different display areas like below:

Pressing times	Model	Descriptions	Display
0	CS III (Factory Settings)	Constant curve, speed III	
1	AUTO	Adaptive mode	
2	PP I	Proportional pressure curve, speed I	
3	PP II	Proportional pressure curve, speed II	
4	PP III	Proportional pressure curve, speed III	
5	CP I	Constant pressure curve, speed I	
6	CP II	Constant pressure curve, speed II	
7	CP III	Constant pressure curve, speed III	
8	CS I	Constant curve, speed I	
9	CS II	Constant curve, speed II	
10	CS III	Constant curve, speed III	
/	PWM	External control of motor speed	

3 Cautions

Warning

- Ground motor before connecting to power supply. Do not touch the pump while it is running.
- Do not run the pump without water.

- 3.1 The power supply voltage of the electric pump is single phase 220~240V, and the frequency is 50/60hz.
- 3.2 Make sure that the pipe system is securely connected before installation and verify that the impurities, soldering leftover and wastes have been cleaned within the pipes.
- 3.3 Make sure the pump is located in dry and ventilation environment to avoid short circuit due to moisture or splashing into the casing, and guarantee its availability to service and replacement.
- 3.4 The protection cover must be added, for the requirement of outdoor installation, while actions must be taken to avoid being splashed and to prevent electric shock risk in indoor installation. Warning: do not install in bathroom to prevent vapor or water or moisture from going into the junction box resulting in electric leakage.
- 3.5 It's strongly suggest that shutoff valves to be installed at inlet and outlet ports for the sake of following pump service and maintenance.
- 3.6 When complete installing the pump, connect the power supply as pilot run and set the speed adjusting switch at max grade to check if the starting is normal. But the pilot running time can not be over 10 seconds so as to avoid idle running influencing working life of the bearing.
- 3.7 When the pump is supplying water to the heating system, do not touch the pump and/or other pipes to avoid burning.
- 3.8 The power plug must be strictly grounded. Securely connect the GND pin of the power plug to the power plug grounded hole. Do not attempt to change the GND plug of the pump.
- 3.9 The striking security caution markings must be set up during pump working to avoid any accident.
- 3.10 The power supply must be firstly disconnected before adjusting pump location or before any action that may touch the pump when the pump is working to avoid any accident.
- 3.11 Regularly check the pump and timely replace in case of any damage.
- 3.12 The power cable can only be replaced with corresponding cords or dedicated components.
- 3.13 In winter, when the environment temperature is below 0, the water within the pipes must be exhausted thoroughly if the pump ceases working to avoid pump frost crack.
- 3.14 The heat supply pipes can not be frequently supplemented with non-soft water to avoid the accumulated calcium inside the pipe system that that may block the rotor.

4 Using environment and installation

4.1 Pumped liquids

The conveying medium is the softened water and thin, clean, non-corrosive, non-explosive liquid without solid particles, fiber and mineral oil. The PH is 6.5-8.

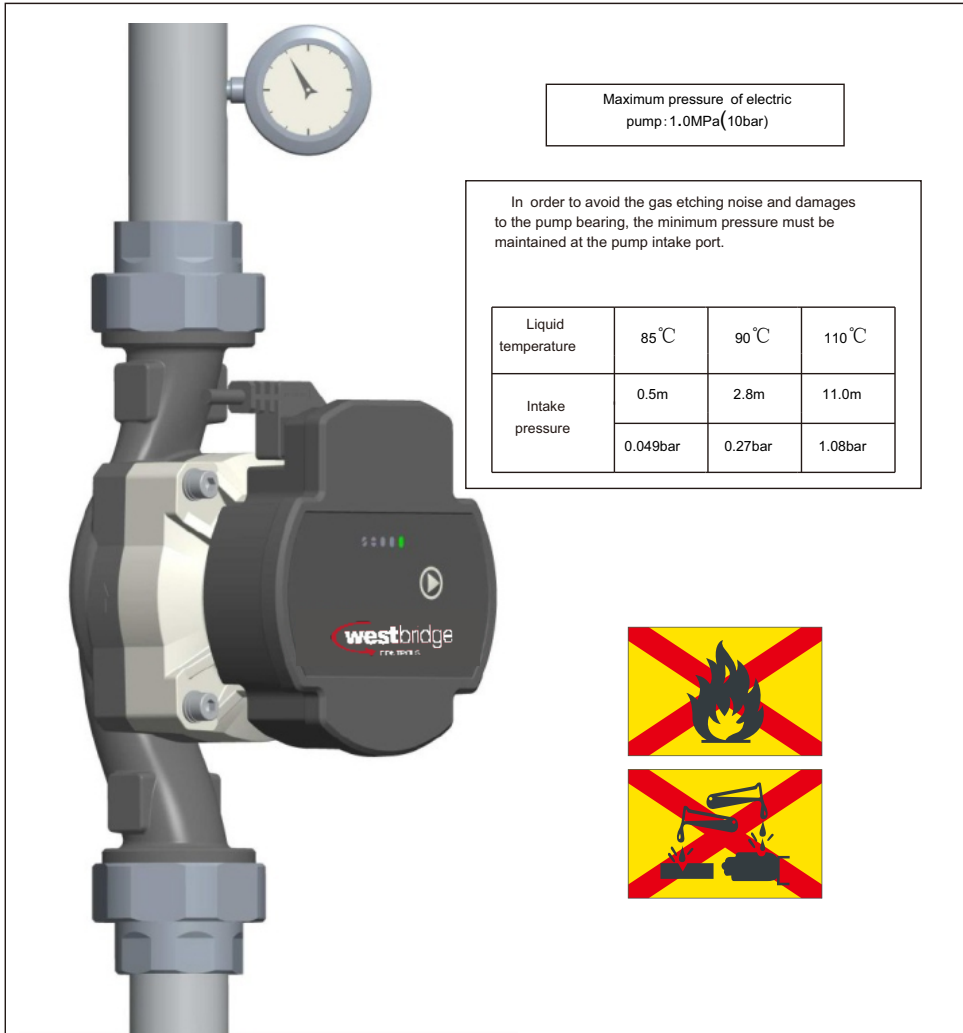

5.2 Performance curve

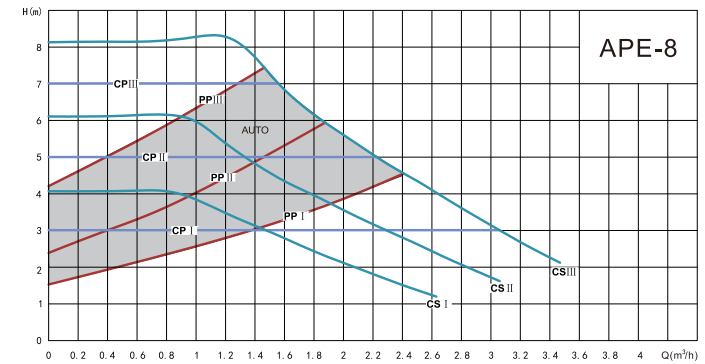
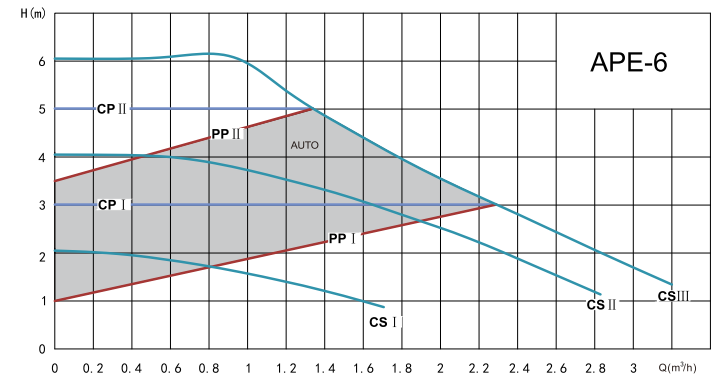
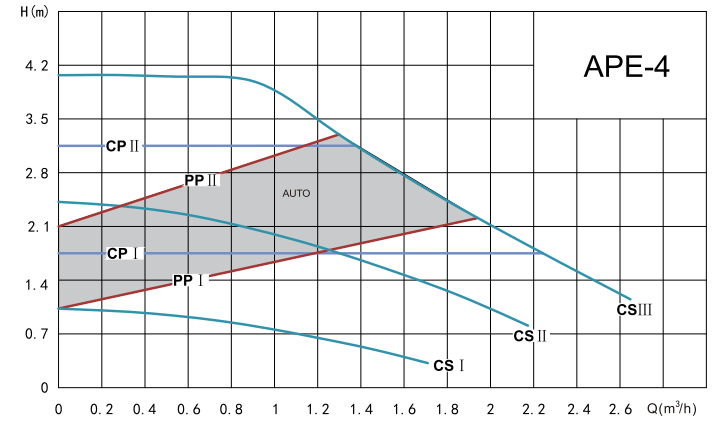

4.5 Electrical connection

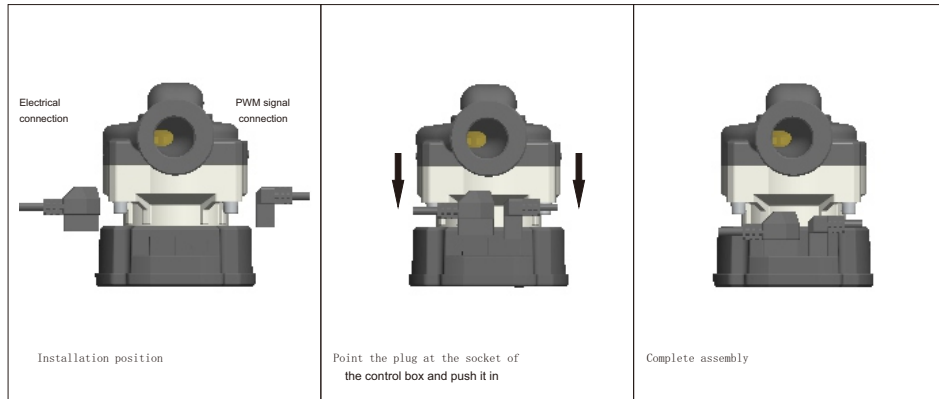

5 Operation instructions

5.1 The control panel

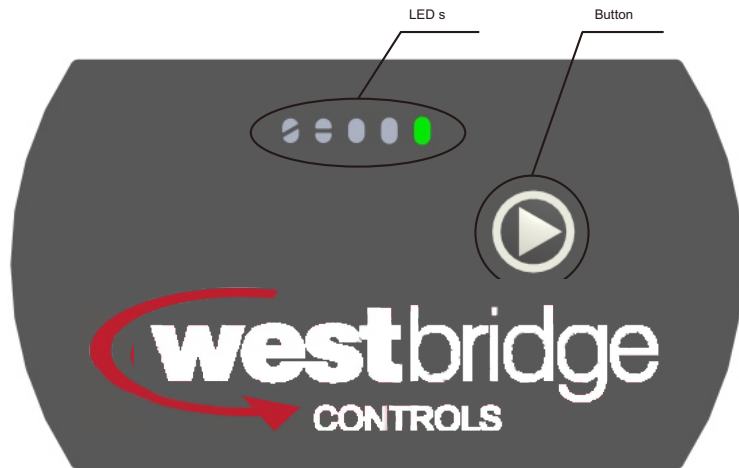

4.2 Liquid temperature and ambient temperature

Liquid temperature(t) (°C) ₁	2~110
Ambient temperature (t) (°C) ₂	0~40

4.3 Installation

The motor shaft must be kept in horizontal direction when installing, the liquid flowing direction in pipe must be same with the arrow marked on pump body.

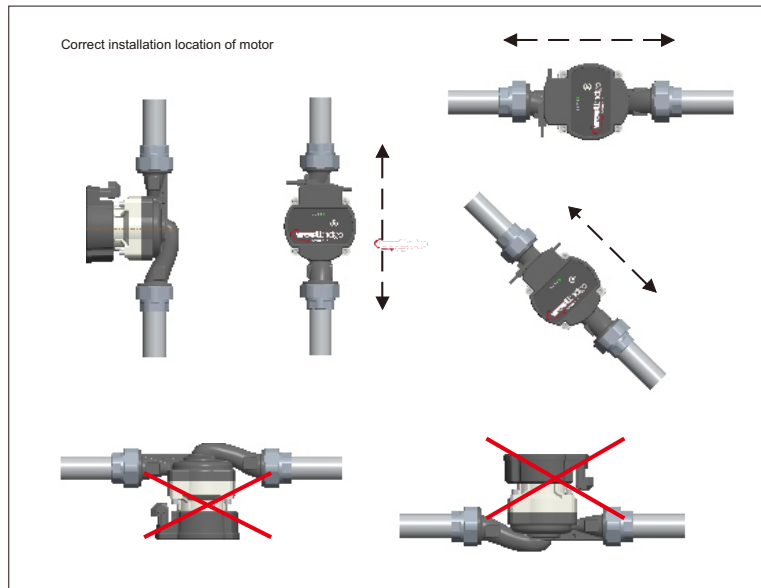
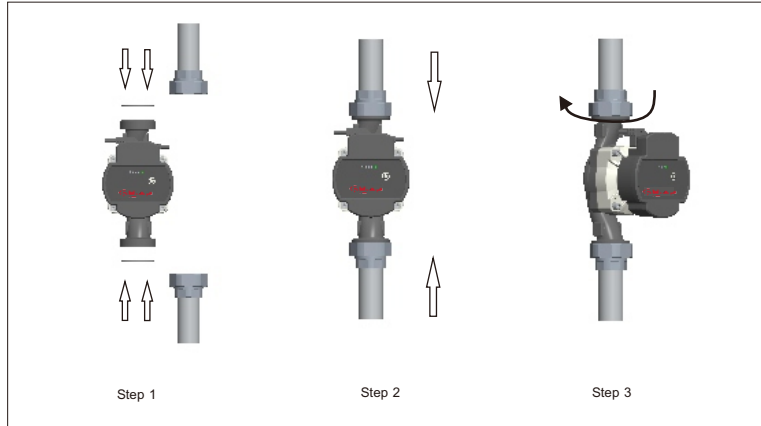

4.4 Control box positions

The following operations can only be completed by qualified personnel.

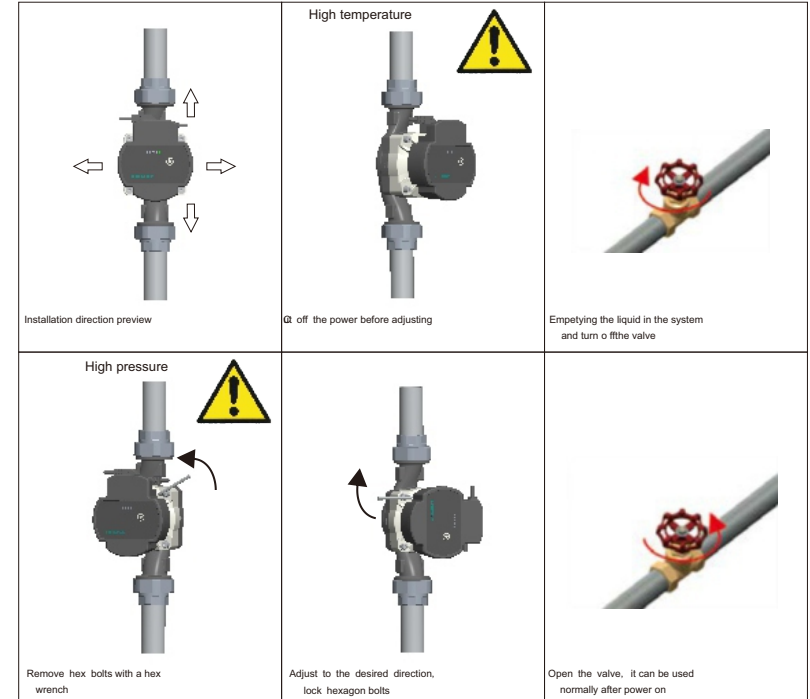

Pumped liquid may be high temperature, high pressure liquid. Before removing the hexagon socket screw, drain the hot water in the system and close the intercepting valve on both sides Warning of the electric pump.